

CHICAGO FAUCETS®

2100 SOUTH CLEARWATER DRIVE
DES PLAINES, ILLINOIS 60018-5999

Last As Long As The Building

FITTING NO.

335-X

SUBMITTED MODEL NO.

JOB NAME

ITEM NO.

SUBMITTED AS SHOWN

SUBMITTED AS NOTED

SEE ATTACHED FOR
SUBMITTED MODIFICATION

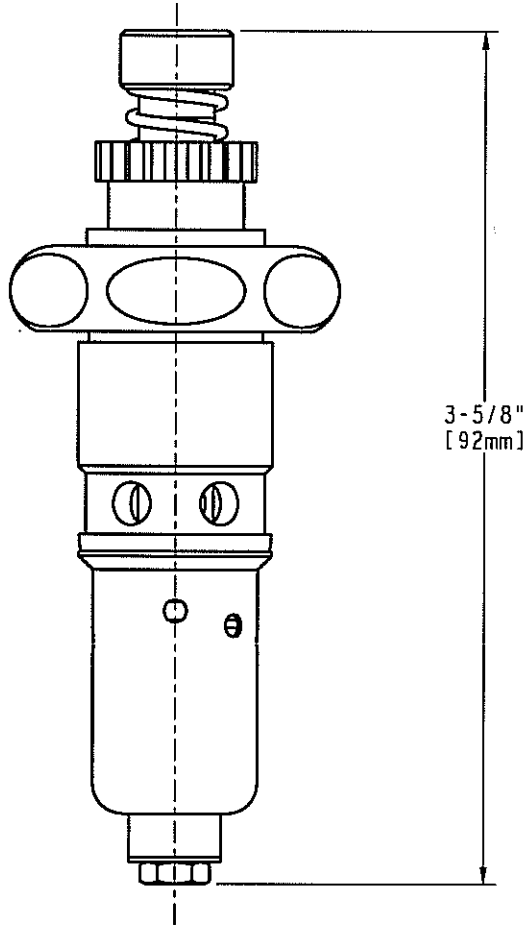

3-5/8"
[92mm]

DIMENSIONS IN INCHES AND [MILLIMETERS].

TECHNICAL DATA

TIP-TAP CARTRIDGE WITH ADJUSTABLE
SLOW CLOSING DASHPOT FOR EXPOSED VALVE
NOTE: 335-007K (HOT), 335-107K (COLD),
OR 335-207K (PUSH) HANDLES NOT INCLUDED

DATE: 11-19-02

BY: SID

CHK'D: *AT*

APP'D:

REV: A

335-X

ROUGHING IN DIMENSIONS MAY VARY AND ARE SUBJECT TO CHANGE. NO RESPONSIBILITY IS ASSUMED FOR USE OF SUPERCEDED OR VOIDED DATA.